

ECM-3455J

Intel® J3455 SoC

3.5 Inch Single Board Computer (SBC)

User's Quick Start Card

Version 1.01

<http://www.bcmcom.com>



ECM-3455J

• Responsibility:

This manual is provided "As-Is" with no warranties of any kind, it will neither expressed or implied, including, but not limited to the implied warranties or conditions of this product's fitness for any particular purpose. In no event shall we be liable for any loss of profits, loss of business, loss of data, interruption of business, or indirect, special, incidental, or consequential damages of any kind, even the possibility of such damages arising from any defect or error in this manual or product. We reserve the right to modify and update the user manual without prior notice.



WARNING: CMOS Battery Damage

Replace your system's CMOS RAM battery only with the identical CR-2032 3V Lithium-Ion coin cell (or equivalent) battery type to avoid risk of personal injury or physical damage to your equipment. Always dispose of used batteries according to the manufacturer's instructions, or as required by the local ordinance (where applicable). The damage due to not following this warning will void your motherboard's manufacturer warranty.

Perchlorate Material- Special Handling May Apply.

See <http://www.dtsc.ca.gov/hazardouswaste/perchlorate/>



ATTENTION: Incorrect BIOS Setup

If you do not know how to handle BIOS setup or how to set it up properly, it is strongly advisable that you do not modify any of the settings than otherwise instructed in the User's Quick Start Card. Even a seemingly small incorrect adjustment or modification in the BIOS setup can render your system unstable or unusable. The incorrect BIOS setup is not covered by your motherboard's manufacturer warranty.

• Additional Information:

Additional information on setting this board up can be found in the User's Manual in the provided CD-ROM. The Online User's Manual and FAQ/Knowledge Base can be found on our website by visiting our website: <http://www.bcmcom.com>. If your question is not answered in our FAQ/Knowledge Base, visit our forums and post your messages or submit a new FAQ through FAQ Submittal form for us to add your question in our FAQ with our answer.



WARNING: Electrostatic Sensitive Device (ESD)

Static electricity can easily damage your motherboard and will void your motherboard warranty. Keep the motherboard and other system components in their anti-static packaging until you are ready to install them. Touch a grounded surface before you remove any system component from its protective anti-static packaging. Unpacking and installation should be done on a grounded, anti-static mat. The operator should be wearing an anti-static wristband, grounded at the same points as the anti-static mat. During configuration and installation touch a grounded surface frequently to discharge any static electrical charge that may have built up in your body. Avoid touching the components when handling the motherboard or a peripheral card. Handle the motherboard and peripheral cards either by the edges or by the peripheral card case-mounting bracket.



WARNING: Misplaced Jumper Damage

Incorrect setting jumpers and connectors may lead to damage to your motherboard and will void your motherboard warranty. Please pay special attention not to connect these headers in wrong directions. DO NOT change ANY jumpers while the motherboard has the power!

Application Notes:

Please read the following application notes before proceed with the system setup and/or OS installation:

1. Windows 10 Drivers Installation

It is recommended to load the ECM-3455J drivers with following sequence:

1. Install "Intel INF Driver".
2. Install "Intel Video Driver".
3. Install "Realtek LAN Driver".
4. Install "Realtek Audio Driver".
5. Install "Intel TXE Driver".
6. Install "Intel Serial IO Driver".
7. Make sure there is no exclamation mark shown for any device under Windows "Device Manager".

NOTE:

1. If any of the driver listed above can't be installed, you may update Win10 to the latest version through Windows Update by connecting ethernet cable to one of two ECM-3455J onboard LANs.
2. If the Intel video driver is installed, and the video installer shows again after the system reboot, just close it.
3. Win10 user may download "Intel Graphics Command Center" app from MS Store in order to access the Intel video settings directly.

2. Boot Mode

The default boot mode is set as "UEFI". If you want to switch the boot mode to "Legacy", it can be changed through BIOS option "Boot"->"Boot Mode Select". Then save and exit BIOS once in order for the new boot mode to take effect.

3. Video Support

1. Under UEFI boot mode: The HDMI and LVDS will provide video signal simultaneously.
2. Under Legacy boot mode: Only either HDMI (default) or LVDS provides video signal. (if LVDS panel is attached, please disconnect the HDMI monitor connection to ECM-3455J board in order for the video signal to be switched to the LVDS panel).

4. Dual Role (OTG) Support

The "Port 0" of "F_USB2" header (the USB port pin 2, 4, 6, 8, 10, right next to the SATA header) can support Dual Role when:

1. Set the BIOS option "Advanced"->"XDCI Support" to "Device Mode", then save and exit BIOS.

NOTE:

1. Dual Role is recommended to be used under Android or Linux OS with its own Dual Role driver support.
2. Win10 doesn't provide Dual Role driver support.

5. eDP Support (Available with ECM-3455J eDP version ONLY)

For eDP version of ECM-3455J:

1. Connect the eDP panel signal cable to “LVDS” header.
2. Connect the backlight control cable to “BACKLIGHT” header.
3. There is no eDP BIOS related setting required.

6. PXE Boot

A. In “UEFI” Mode:

1. Under BIOS option “Boot”->”Boot mode select”; change it to “UEFI”.
2. Under BIOS option “Advance”->”Network Stack Configuration”:
 - a. Change “Network Stack” to “Enabled”.
 - b. Enable “Ipv4 PXE Support”.
3. Save and exit BIOS.
4. After system reboot, enter BIOS again.
5. Under BIOS option “Boot”->”UEFI NETWORK Drive BBS Priorities”, set the desired PXE LAN port as “Boot Option #1”.
(NOTE: a. LAN1 (the one next to USB ports) is described as “PXE iP4 Realtek PCIe GBE Family Controller (LAN1)” under BIOS “UEFI NETWORK Drive BBS Priorities” list.
b. LAN2 (the one next to audio port) is described as “PXE iP4 Realtek PCIe GBE Family Controller (LAN2)” under BIOS “UEFI NETWORK Drive BBS Priorities” list.)
6. Press “ESC” key to get back to “Boot” menu.
7. Under BIOS option “Boot”->”Boot Option #1”; change the 1st boot device to the desired PXE LAN that selected under step 5.
8. Save and Exit BIOS.
9. The system will be prompted with message “Check media presence....” and establish link with PXE server.

B. In “Legacy” Mode:

1. Under BIOS option “Boot”->”Boot mode select”; change it to “Legacy”.
2. Save and exit BIOS.
3. After system reboot, enter BIOS again.
4. Under BIOS option “Boot”->”NETWORK Drive BBS Priorities”, set the desired PXE LAN port as “Boot Option #1”.
(NOTE: a. LAN1 (the one next to USB ports) is described as “Realtek PXE B02 D00” under BIOS “NETWORK Drive BBS Priorities” list.
b. LAN2 (the one next to audio port) is described as “Realtek PXE B03 D00” under BIOS “NETWORK Drive BBS Priorities” list.)
5. Press “ESC” key to get back to “Boot” menu.
6. Under BIOS option “Boot”->”Boot Option #1”; change the 1st boot device to the desired PXE LAN that selected under step 4.
7. Save and Exit BIOS.
8. The system will be prompted with PCIe version and establish link with PXE server.

7. The “SPEAKER” Header

The “SPEAKER” header supports 4 ohms/ 2W speaker.

8. The MIC support under Win10

The rear audio port supports “headset” (the headphone with lineout + microphone) with 3 black rings (OMTP or CTIA types).

Here is the installation procedure for MIC support under Win10 environment:

1. Install BCM provided ECM-3455J specific Realtek Win10 audio driver.
2. When the headset is plug-in to ECM-3455J rear audio port; the system will be prompted for the selection of “Headset” or “Headphone”, **Please select “Headset” ONLY.**
3. The Realtek HD Audio Manager will be prompted and displays the “Microphone” icon. The microphone on the plugged-in headset is ready to use.

Motherboard Layout:

- Board Layout (Top View):

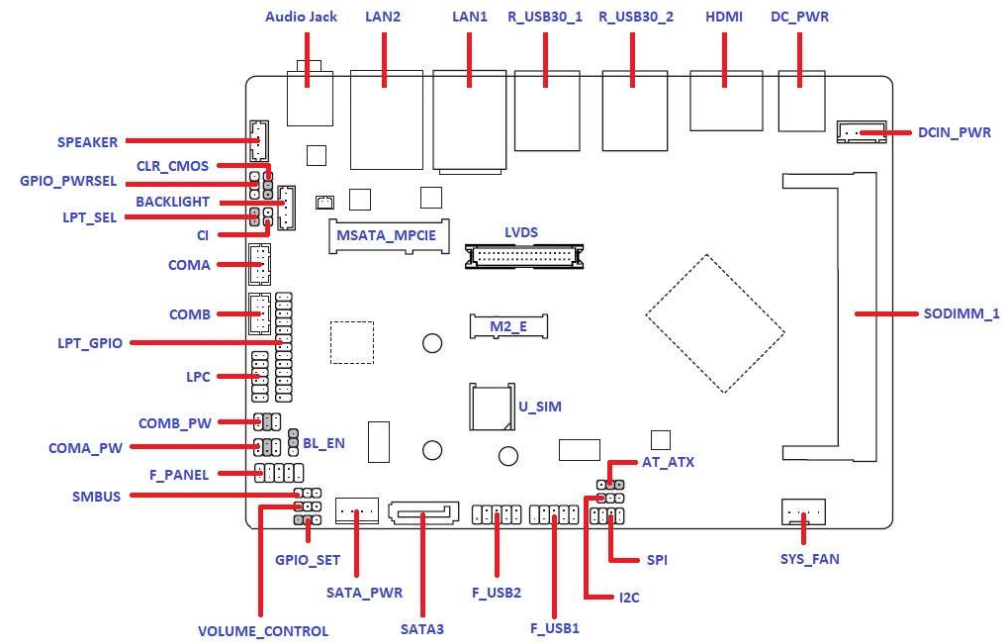

• Back Panel (Rear I/O Ports):

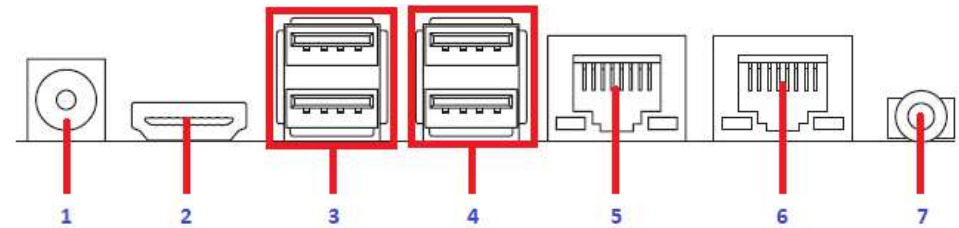

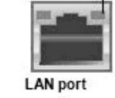
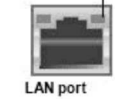
Item	Name	Function	Description																				
1	DC_PWR	DC-In Jack	DC-In Jack for AC Adapter Power Connection. (9V~36V, 6A max. 19V recommended)																				
2	HDMI	HDMI Port	The HDMI Port Connector.																				
3	R_USB30_2	USB3.0 Ports	The USB3.0 Port Connectors.																				
4	R_USB30_1	USB3.0 Ports	The USB3.0 Port Connectors.																				
5	LAN1	Gigabit LAN (RJ-45) Connectors  LAN port	This port allows Gigabit connection to a Local Area Network (LAN) through a network hub. Refer to the table below for the LAN port LED indications. <table border="1"> <thead> <tr> <th colspan="2">ACT/Link LED</th> <th colspan="2">Speed LED</th> </tr> <tr> <th>Status</th> <th>Description</th> <th>Status</th> <th>Description</th> </tr> </thead> <tbody> <tr> <td>OFF</td> <td>No link</td> <td>OFF</td> <td>10Mbps connection</td> </tr> <tr> <td>Orange</td> <td>Linked</td> <td>Green</td> <td>100Mbps connection</td> </tr> <tr> <td>Blinking</td> <td>Data activity</td> <td>Orange</td> <td>1Gbps connection</td> </tr> </tbody> </table>	ACT/Link LED		Speed LED		Status	Description	Status	Description	OFF	No link	OFF	10Mbps connection	Orange	Linked	Green	100Mbps connection	Blinking	Data activity	Orange	1Gbps connection
ACT/Link LED		Speed LED																					
Status	Description	Status	Description																				
OFF	No link	OFF	10Mbps connection																				
Orange	Linked	Green	100Mbps connection																				
Blinking	Data activity	Orange	1Gbps connection																				
6	LAN2	Gigabit LAN (RJ-45) Connectors  LAN port	This port allows Gigabit connection to a Local Area Network (LAN) through a network hub. Refer to the table below for the LAN port LED indications. <table border="1"> <thead> <tr> <th colspan="2">ACT/Link LED</th> <th colspan="2">Speed LED</th> </tr> <tr> <th>Status</th> <th>Description</th> <th>Status</th> <th>Description</th> </tr> </thead> <tbody> <tr> <td>OFF</td> <td>No link</td> <td>OFF</td> <td>10Mbps connection</td> </tr> <tr> <td>Orange</td> <td>Linked</td> <td>Green</td> <td>100Mbps connection</td> </tr> <tr> <td>Blinking</td> <td>Data activity</td> <td>Orange</td> <td>1Gbps connection</td> </tr> </tbody> </table>	ACT/Link LED		Speed LED		Status	Description	Status	Description	OFF	No link	OFF	10Mbps connection	Orange	Linked	Green	100Mbps connection	Blinking	Data activity	Orange	1Gbps connection
ACT/Link LED		Speed LED																					
Status	Description	Status	Description																				
OFF	No link	OFF	10Mbps connection																				
Orange	Linked	Green	100Mbps connection																				
Blinking	Data activity	Orange	1Gbps connection																				
7	Audio Jack	Line-out / MIC port	This port connects a headset (audio jack with 3 black rings (OMTP or CTIA types) or speaker. NOTE: Check "Application Notes" section #8 for details.																				

Jumpers, Connectors, & Headers:

• 4-Pin Power Connector: DCIN_PWR

NOTE: 1. If AC adapter is connected with “DC_PWR” connector at rear IO, then this 4-pin connector doesn't need any power connection.

2. A 4-pin to AC adapter barrel connector cable is required when utilizing this header as the only power source to ECM-3455J board.

3. 9V~36V, 6A Max. 19V recommended.

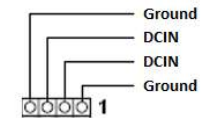
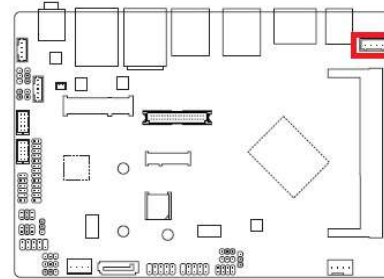

• ATX/ AT Mode Select: AT_ATX

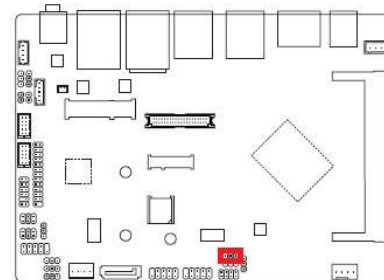

Pin 1-2: AT Mode
Pin 2-3: ATX Mode (Default)

• Front Panel Connector: F_PANEL

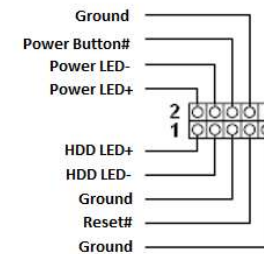
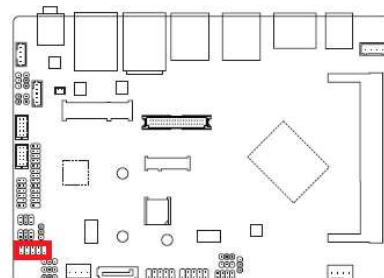

• System Fan Connector: SYS_FAN

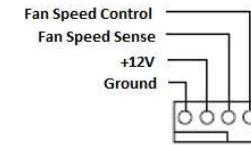
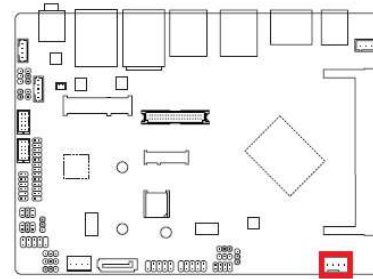

• SATA3 Connector: SATA3

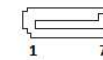
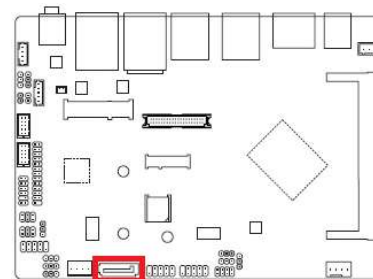

Pin No.	Definition
1	GND
2	TXP
3	TXN
4	GND
5	RXN
6	RXP
7	GND

• SATA Power Connector: SATA_PWR

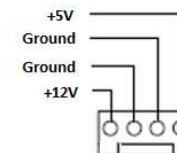
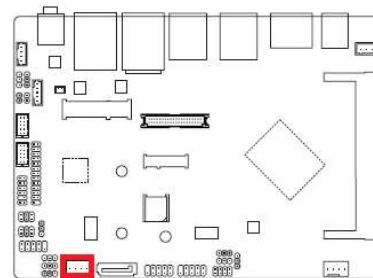

• mSATA/ Mini-PCIE Connector: MSATA_MPCIE

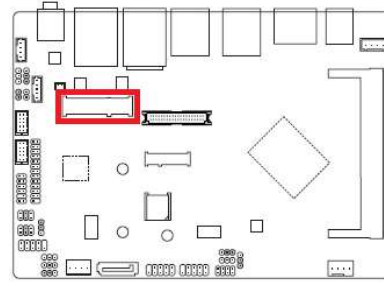

• uSIM Card Slot: U_SIM

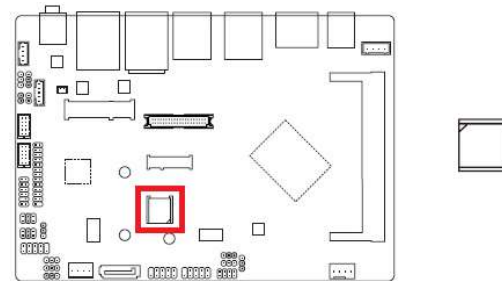

• M.2 Socket: M2_E (E-Key, Supports Wifi Cards in 2230 Only)

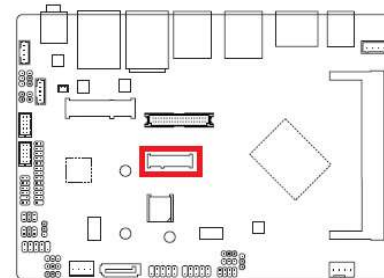

• **USB2.0 Headers: F_USB1, F_USB2**

NOTE: "F_USB2" header port 0 (the USB set on pin 2, 4, 6, 8, 10 only) supports Dual Role (OTG) when BIOS "XDCI Support" is set on "Device Mode".

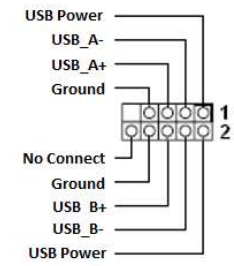
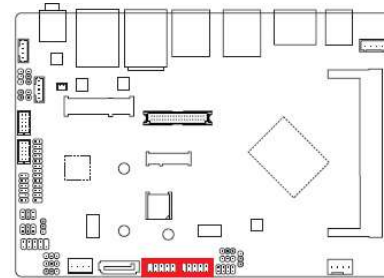

• **COM Ports: COMA, COMB**

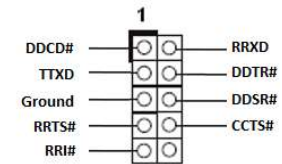
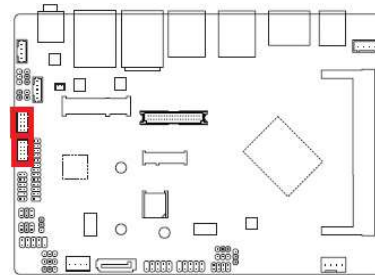

• **COM Port +12V/ +5V/ Ring-In Select: COMA_PW, COMB_PW**

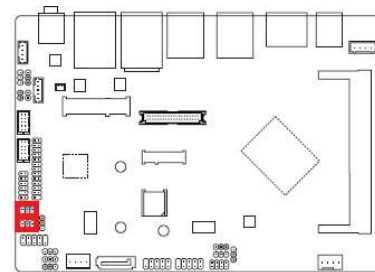

Pin 1-2: +12V
 Pin 3-4: Ring-In (Default)
 Pin 5-6: +5V

• LVDS Panel Connector: LVDS

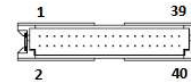
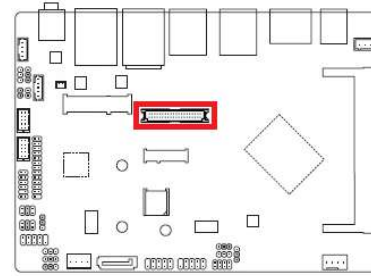

PIN	Signal Name	PIN	Signal Name
2	VDD_+5V	1	VDD_+3.3V
4	VDD_+5V	3	VDD_+3.3V
6	DDC_DATA	5	DDC_CLK
8	GND	7	GND
10	LVDS_A0+	9	LVDS_A1+
12	LVDS_A0-	11	LVDS_A1-
14	GND	13	GND
16	LVDS_A2+	15	LVDS_A3+
18	LVDS_A2-	17	LVDS_A3-
20	GND	19	GND
22	LVDS_B0+	21	LVDS_B1+
24	LVDS_B0-	23	LVDS_B1-
26	GND	25	GND
28	LVDS_B2+	27	LVDS_B3+
30	LVDS_B2-	29	LVDS_B3-
32	GND	31	GND
34	LVDS_A_CLK+	33	LVDS_B_CLK+
36	LVDS_A_CLK-	35	LVDS_B_CLK-
38	GND	37	GND
40	VDD_+12V	39	VDD_+12V

• LVDS Backlight Connector: BACKLIGHT

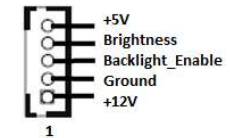
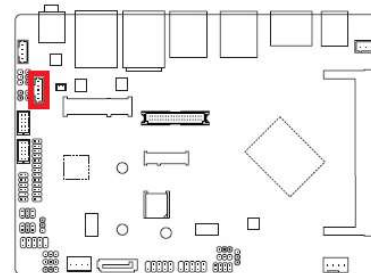

• LVDS Backlight Enable Voltage Select: BL_EN

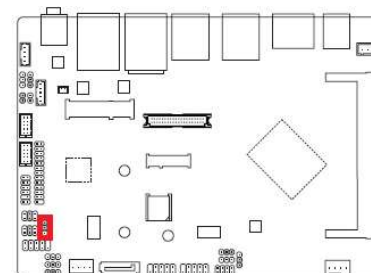

• I2C Header: I2C

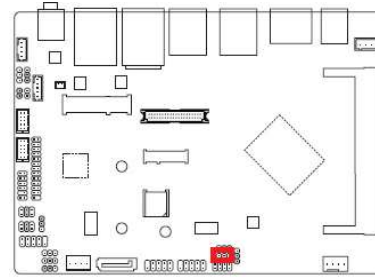

Pin No.	Definition
1	I2C_SCL
2	I2C_SDA
3	GND

• SPI Header: SPI

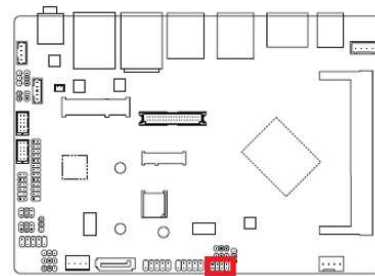

Pin No.	Definition	Pin No.	Definition
1	VCC1_8VDUAL	5	SPI_MISO_R
2	GND	6	SPI_MOSI_R
3	-SPI_CS0_R	7	-SPI_HOLD_R
4	SPI_CLK_R	8	-SPI_WP0_R

• SMBUS Header: SMBUS

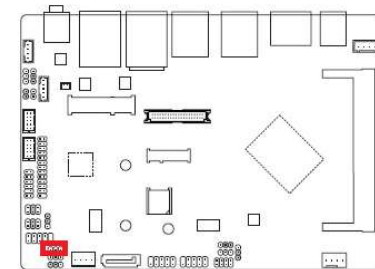

Pin No.	Definition
1	SMB_CLK
2	SMB_DATA
3	GND

• Volume Control Header: **VOLUME_CONTROL**

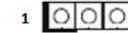
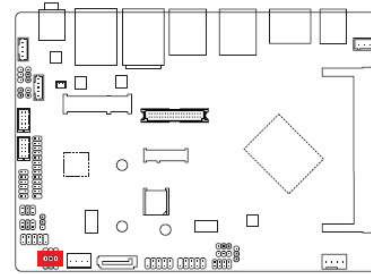

Pin No.	Definition
1	VOL_DOWN
2	GND
3	VOL_UP

• GPIO High/ Low Select: **GPIO_SET**

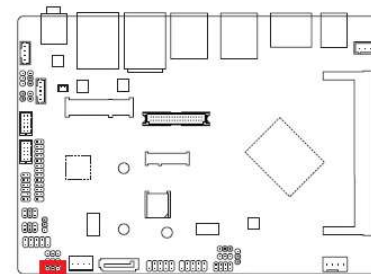

Pin 1-2: High (+3V, Default)
Pin 2-3: Low

• LPT/ GPIO Header: **LPT_GPIO**

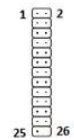
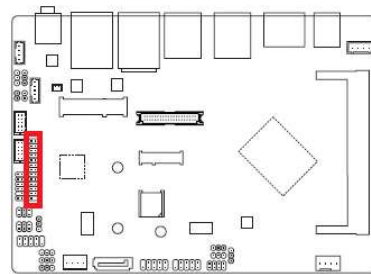

LPT Mode

Pin #	Signal Name	Pin #	Signal Name
1	STB-	2	AFD-
3	PD0	4	ERR-
5	PD1	6	INIT-
7	PD2	8	SLIN-
9	PD3	10	GND
11	PD4	12	GND
13	PD5	14	GND
15	PD6	16	GND
17	PD7	18	GND
19	ACK-	20	GND
21	BUSY	22	GND
23	PE	24	GND
25	SLCT	26	NC

GPIO Mode

Pin #	Signal Name	Pin #	Signal Name
1	SIO_GP47	2	SIO_GP46
3	SIO_GP42	4	SIO_GP45
5	SIO_GP41	6	SIO_GP44
7	SIO_GP40	8	SIO_GP43
9	SIO_GP37	10	GPIOPWR
11	SIO_GP36	12	GPIOPWR
13	SIO_GP35	14	GND
15	SIO_GP34	16	GND
17	SIO_GP33	18	GND
19	SIO_GP32	20	GND
21	SIO_GP31	22	GND
23	SIO_GP30	24	GND
25	NC	26	NC

• LPT/ GPIO Selection for header “LPT_GPIO”: LPT_SEL

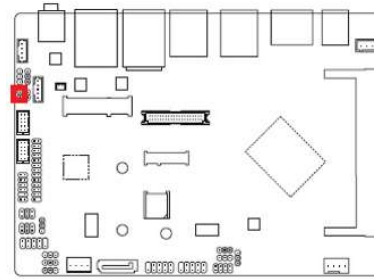

Short Pin 1-2: Configure the LPT_GPIO header to support LPT device.

Removed jumper connector on pin 1-2: Configure LPT_GPIO header in GPIO mode (Default).

• LPC Header: LPC

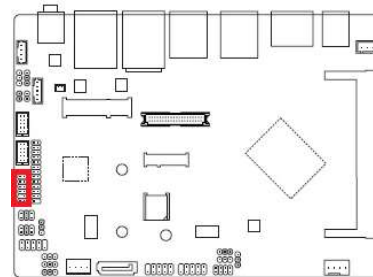

Pin No.	Definition	Pin No.	Definition
1	NC	7	-LFRAME
2	VCC3	8	LAD0
3	LAD3	9	No Pin
4	-PFMRST	10	GND
5	LAD1	11	LPC33
6	LAD2	12	GND

• GPIO Power Select: GPIO_PWRSEL

NOTE: When “LPT_GPIO” header is set in GPIO mode, this jumper selects its pin #10, 12 “GPIOPWR” (GPIO Power) at the level of +12V or +5V (default).

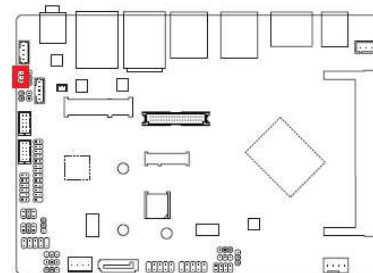

Pin 1-2: Set GPIO voltage to +12V.



Pin 2-3: Set GPIO voltage to +5V (Default).

• **SPEAKER Header: SPEAKER**

NOTE: supports 4 ohms/ 2W speaker.

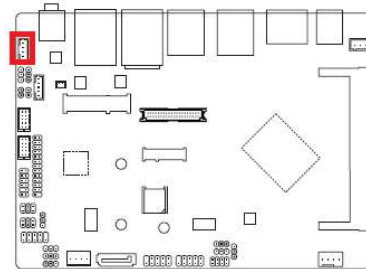

Pin No.	Definition
1	Speaker OUT R-
2	Speaker OUT R+
3	Speaker OUT L-
4	Speaker OUT L+

• **Chassis Intrusion Header: CI**

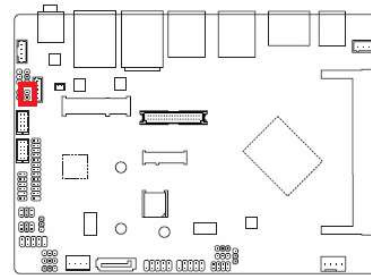

Pin No.	Definition
1	Signal
2	GND

• **Clear CMOS Jumper: CLR_CMOS**

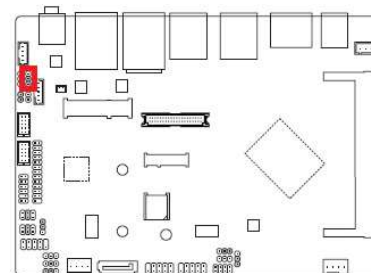

Pin 1-2: Clear CMOS
Pin 2-3: Normal (default)

- **Save the Processor Socket Cover**

After removing the processor cover during processor installation, please save the processor socket cover. In the event that the desktop board needs to be returned for service or any time the processor is removed, the cover should be replaced on the processor socket.

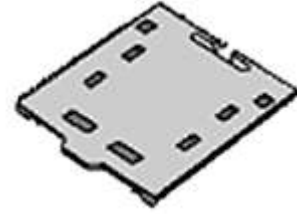

- **Do not Touch Socket Contact**

